

Claw Cleat (Cast Iron)

370 Series



The cast iron claw cleat is the premium choice for fire performance cables. Suitable for all cable routes, the claw cleat can tolerate a two hour excursion of up to 1000°C.



Features and benefits

- Suitable for use with cable diameters 10 - 54mm.
- Hot dip galvanised finish on cast iron.
- Two-piece, single fixing design.
- Can be stacked to a maximum of three on one fixing.
- Operating temperature -60°C to +105°C.
- Can withstand a 2 hour excursion to 1000°C.
- Can be used for all types of cable routes.
- Suitable for all environments.
- Packing pieces to be used where required.
- LUL APR Product ID 1961.
- Allows fire performance cables to meet the requirements of BS 8519:2020, BS 5266-1:2016, BS 5839-1:2017, BS 8491:2008 & BS 6387:2013

Performance Data

Test Standard	EN50368:2003
Type	6.1.1 Metallic
Impact resistance	6.2.5 V. Heavy
Lateral Load	3.7 -> 8.2kN
Axial Load	1.332 -> 5.855kN
Needle Flame	>120 secs

* Technical Information subject to change without notice



Technical Data



Cable and Cleat Selection			Cleat Details					Weight (g)	Stud size
Design Number	Cable Diameter		Dimensions (mm)						
	A (mm)		B	C	D	E			
	Min	Max	Max						
370CG01	10	13	22	38	46	16	227	M10	
370CG02	13	16	22	38	46	16	208	M10	
370CG03	16	19	25	41	46	18	232	M10	
370CG04	18	22	28	45	46	19	279	M10	
370CG05	21	26	32	48	46	21	299	M10	
370CG06	25	32	37	54	46	24	319	M10	
370CG07	31	38	43	60	46	27	395	M10	
370CG08	36	46	53	67	46	30	492	M10	
370CG09	44	54	59	73	46	33	502	M10	

* Technical Information subject to change without notice

Method of fixing

In all application the cleats should be mounted on suitable fixings, see table for appropriate size. When mounting directly on channel, adaptor plates 380AG02 should be used. When stacking claw cleats use packing piece 389AC01 between cleats.

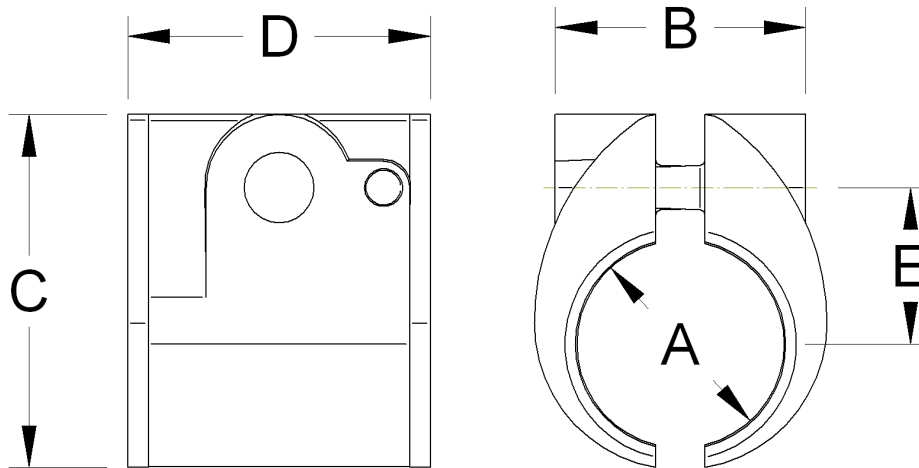

Prysmian Cables & Systems Limited,
Oak Road, Wrexham Industrial Estate, Wrexham, LL13 9PH, UK

Commercial Enquiries,
Sales Office Tel: 0845 767 8345,
International Sales Office Tel: +44 2380 295481

www.biconcomponents.co.uk