

E1WF-AI Ex d IIC / Ex e II

455AA Series

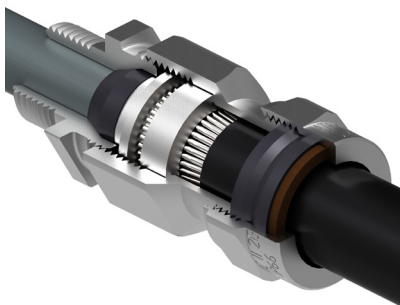

The E1WF weatherproof hazardous area gland is an aluminium dual seal performance cable gland for steel wire armoured cables.



Features and benefits:

- Aluminium indoor and outdoor cable gland for use in hazardous areas
- Suitable for circular, aluminium wire armour cables with extruded polymeric bedding and oversheath
- Achieves IP66 seal onto cable and to enclosure with suitable sealing washer or thread sealant
- Three part armour lock provides mechanical cable retention and electrical continuity
- Inner PCP seal grips cable bedding and provides additional ingress protection
- Suitable for most climatic conditions - weatherproof and waterproof
- Full Installation Instructions supplied

Technical Information:

Certified II 2GD, Ex e II & Ex d IIC under ATEX directive 94/9/EC

Atex Compliance Standards: EN 60079-0, EN 60079-1, EN 60079-7, EN 61241-0, EN 61241-1

Certificate number Sira 02ATEX3092X

IECEX Compliance Standards: IEC 60079-0, IEC 60079-1,

IEC 60079-7, IEC 61241-0, IEC 61241-1

Certificate number IECEX SIR 10.0071X

Service temperature range -60°C to +90°C

May be used in:

- Zones 0, 1 & 2 with Ex ia IIA, B & C equipment
- Zones 1 & 2 with Ex ib IIA, B & C equipment
- Zones 1 & 2 with Ex e II equipment
- Zones 2 with Ex nA II equipment
- Zone 21 & 22 with Ex tD A21

Where the cable is effectively filled, may Also be used in:

- Zones 1 & 2 with Ex d IIC equipment not containing a source of ignition & with a volume less than 2000cm³
- Zones 1 & 2 with Ex d IIA & Ex d IIB equipment not containing a source of ignition & with any volume
- Zone 1 with Ex d IIA & Ex d IIB equipment containing a source of ignition & with a volume less than 2000cm³
- Zone 2 with Ex d IIA & Ex d IIB equipment containing a source of ignition & with any volume
- Zone 2 with Ex nR II equipment

Specifications

Gland Kit Reference		Cable Dimensions mm					Gland Dimensions mm				
Design Reference	Size	Under Armour Ø (A)		Overall Ø (B)		Armour Wire ø	Entry Thread (D)	Thread Length (E)	Protrusion Length (F)	Hexagon	
		Min	Max	Min	Max					A/F (G)	A/C (H)
Standard	16	3.8	8.7	8.0	13.2	0.9	M16 × 1.5	15	41	23.4	26.7
455AA-51	16	3.8	8.7	8.0	13.2	0.9	M16 × 1.5	15	41	23.4	26.7
455AA-71	20SS	3.8	8.7	8.0	13.2	0.9	M20 × 1.5	15	41	23.4	26.7
455AA-52	20S	8.0	11.8	8.0	15.8	0.9 / 1.25	M20 × 1.5	15	43	25.7	29.2
455AA-53	20	11.8	14.2	11.7	20.8	0.9 / 1.25	M20 × 1.5	15	43	30.5	34.0
455AA-55	25	14.0	20.1	17.0	27.2	1.25 / 1.6	M25 × 1.5	15	48	37.6	42.2
455AA-56	32	19.7	26.6	23.5	33.5	1.6 / 2.0	M32 × 1.5	15	53	47.2	53.6
455AA-57	40	26.6	32.4	29.0	39.9	1.6 / 2.0	M40 × 1.5	15	56	56.4	61.5
455AA-58	50S	32.4	38.4	38.0	46.2	2.0 / 2.5	M50 × 1.5	15	61	60.0	66.0
455AA-59	50	38.4	44.3	39.5	52.6	2.0 / 2.5	M50 × 1.5	15	61	70.1	77.2
455AA-60	63S	44.3	50.3	50.0	58.9	2.5	M63 × 1.5	15	64	75.0	83.0
455AA-61	63	50.3	56.2	51.3	65.3	2.5	M63 × 1.5	15	64	80.0	87.4
455AA-62	75S	56.2	62.2	62.0	71.6	2.5	M75 × 1.5	15	73	90.2	99.1
455AA-63	75	62.2	68.1	62.5	78.0	2.5	M75 × 1.5	15	73	98.8	109.2
455AA-64	85	68.0	74.0	68.0	88.0	3.15	M80 × 2.0	20	102	115.1	126.0

