

Jointing of Signalling Power Cables Article in 'Rail Engineer magazine' Sept-Oct 2022



Prysmian
Group

Linking
the Future



DR. DAVID LAMB &
JONATHAN RAWLINSON

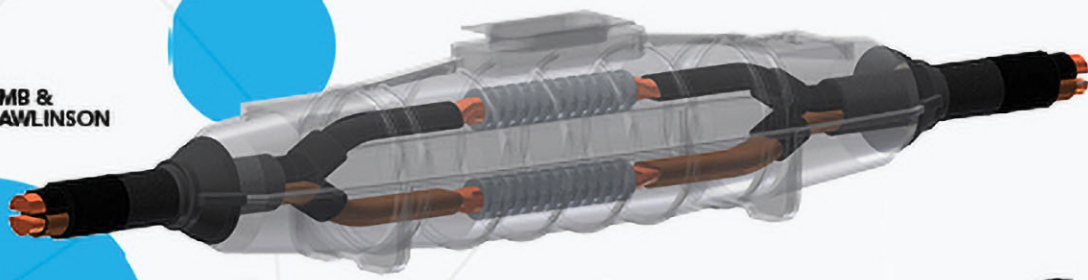

Jointing of signalling power cables what's all the fuss about?

The Network Rail standard for enhanced unarmoured Signalling Power Distribution cables - NR/L2/SIGELP/27408 was introduced to tighten the specification for signalling power cables and support the introduction of class II methodology. The cable standard introduced several key requirements that drive the need to correctly specify the cable and the associated accessories – specifically the joints and jointing methodology used.

The cable standard re-introduces the use of aluminium as a conductor of choice alongside the traditional and more expensive stranded copper option. For the aluminium option NR/L2/SIGELP/27408 specifies solid conductors up to 95mm² and allows both solid and stranded conductors for sizes equal or greater than 120mm². To protect the cable from water and rodent-related degradation, the cable standard requires the use of water blocking tapes and fibreglass-woven rodent resistant tapes.

To supplement NR/L2/SIGELP/27408 and support the required target asset life of 35+ years, specific accessories standards have been written. NR/L2/SIGELP/27423 covers the requirement for cable joints and connectors. The standard says that, to achieve the target asset life, joints using resinous compounds are preferred.

Previous joints history

The history of jointing signalling power cables is chequered – at one end of the scale there are manufacturer assembled, fully compatible and tested joints, which include connectors designed and tested to meet the Network Rail requirements of the day. At the other end of the scale are joints assembled by third parties at the last minute to try to fulfil a particular urgent need, and which may or may not have been approved by Network Rail.

At both ends of this scale there would be a mix of technologies which may or may not produce a reliable installed joint capable of protecting the cable and meeting the Network Rail asset life expectations. This chequered history might have influenced the cautious approach of the industry related to the speed of the reintroduction of aluminium conductors.

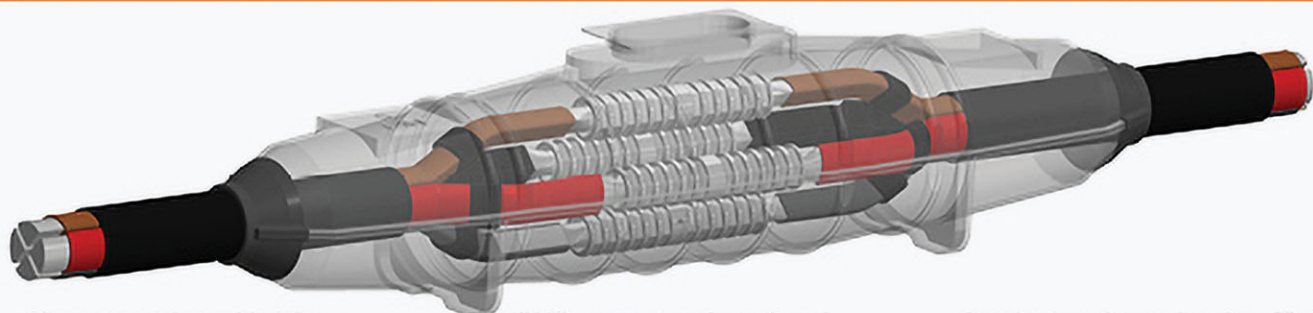

Next generation cable joints

The standard NR/L2/SIGELP/27423 relates to joints intended for connecting signalling power cables, where the electrical system is either TN or IT and the nominal voltage is up to 650VAC. The cable types are defined as follows:

- » a) Enhanced unarmoured cable to NR/L2/SIGELP/27408.
- » b) B2 ethylene propylene rubber (EPR) cable to RT/E/PS/00005.
- » c) Armoured cable to BS 5457.
- » d) Armoured cable to BS 6346.

Within the joints standard, particular attention has been focussed on the conductor connectors or splices which requires full compliance with BS EN 61238-1 for both aluminium and copper conductors:

"Connector resistance, temperature, mechanical strength and short-circuit behaviour shall be in accordance with a Class A connector as specified in BS EN 61238-1." (Network Rail, 2015)

In particular, connections between dissimilar metals, i.e., copper and aluminium, are specified to be made using bi-metallic connectors. These are required by NR/L2/SIGELP/27423 to be made by friction welding and similarly tested and approved to BS EN 61238-1.

Mixed experience

Network Rail has mixed experience with the aluminium conductor type cables leading to a previous preference for the copper conductors. However, driven by the recent high copper prices these cables are significantly more expensive and more liable to theft. Looking outside of the rail sector it was noted that the UK power utilities had been using aluminium conductors and their associated joints and connections without significant problems for over 40 years. It was also recognised that the industry had tight product specification and training requirements in place.

To ensure an equivalent success rate on the product specification, the Network Rail joint standard sets out specific requirements for conductor connections and their installation:

"Unlike copper conductor based distribution systems, aluminium cable is very intolerant of poorly designed and badly made-up connectors. Failure of a connector can lead to loss of the power distribution system, which in turn can cause severe operational disruption. This specification has been developed to ensure that connectors used in signalling power distribution systems are made to a consistent standard and the measures identified in this standard, when adhered to, prevent premature failure." (Network Rail, 2015)

Focussing on installation, the Network Rail accessory standard requires that all connectors supplied shall be suitable for installation in accordance with BS 7609. This is the 'Code of practice for installation and inspection of uninsulated compression and mechanical connectors for power cables with copper or aluminium conductors' and covers installation methodology, tooling and the maintenance and calibration of tooling. The Network Rail standard says that the preferred crimping tools are either battery-powered or electro-hydraulic and includes requirement for auto-checking. It also requires that manufacturers of connectors provide the necessary training packages to support their use.

Prysmian Group has over 40 years' experience in the development and testing of crimp connectors, including our in-house friction welding facility. To fulfil the Network Rail requirements the company

has developed, tested, and qualified a completely new range of copper, aluminium, and bi-metallic connectors specifically to fully meet the Network Rail requirements. These Network Rail-approved connectors are fully compatible with the new Prysmian Group joint range. This means that all of its signalling power joints are supplied with the correct connectors for their application.

The Network Rail standard requires that all joints are compliant with BS EN 50393 and are classified as rigid Type II. As noted, in order to fulfil a target asset life of 35+ years, joints made using resinous compounds are preferred. In addition, to provide adequate flood resistance, the joints must demonstrate that they meet the water immersion tests defined in BS EN 50393. (Note: BS EN 50393 requires joints to function within their parameters after being subjected to immersion for 21 days with a 1 metre head of water.)

In order to ensure useability and safety the Network Rail standard specifically requires that the resinous compounds used shall be classification LMP/LI-LT (Low voltage, Mechanical Protection / Low voltage, Insulation protection and Low Temperature curing) as per the requirements defined in BS 7933-1. In a move to maintain the highest levels of health and safety, the standard requires that the resinous compounds and joint capsules used shall be non-toxic and non-hazardous. »

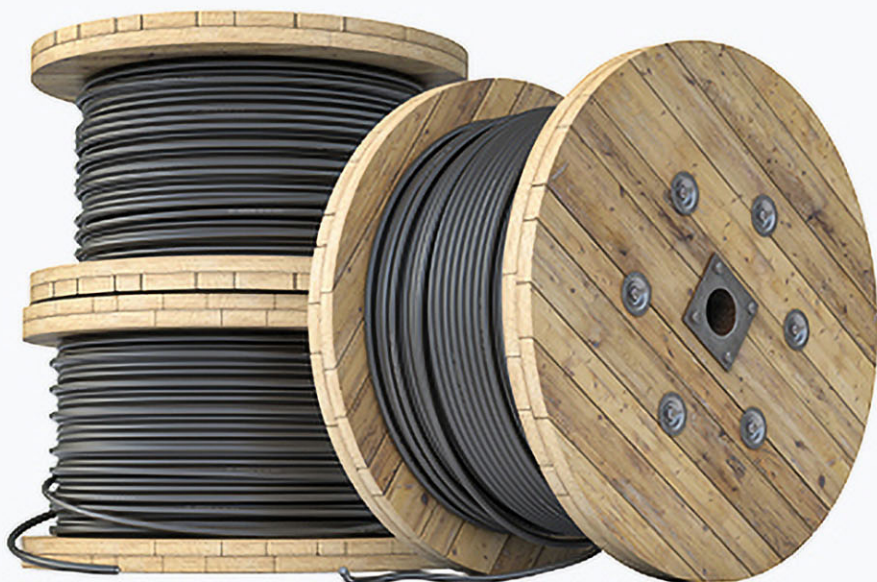

Working in collaboration with the Network Rail approvals team, Prysmian Group has developed and fully product approved a completely new range of NR/L2/SIGELP/27423 and BS EN 50393 compliant joints. These joints utilise the company's enhanced, low hazard, JEM jointing resin. Over 30 million litres of Prysmian Group JEM has been used extensively by many of the UK power utilities, with no electrical failures reported.

Prysmian Group's JEM resin can be mixed and will cure at temperatures as low as -15°C , meeting the Network Rail low temperature curing requirements that may be encountered in the UK climate. It is also a low viscous material which makes it extremely easy to mix, and also extremely searching, minimising any voids that can occur with traditional resins. JEM resin is supplied in clear pouches which allows mixing to be observed during the process enabling the joiner to ensure mixing is complete prior to filling the joints. Another benefit of the JEM system is that when poured the filled joints, if undisturbed, may be energised immediately. From a safety perspective JEM resin is non-volatile, non-flammable, non-irritating and non-sensitising in line with Network Rail expectations.

In order to meet the Network Rail reliability requirements, the joint system was put through the Network Rail product approval process which not only required the product to be fully compliant to BS EN 50393 type II but, by using tools like DFMEA and reliability and maintainability analysis throughout the development process, looks at ensuring the robustness of the product. In order to support this robust approach, it is a requirement that the joints are supplied with a detailed set of installation instructions which include stage-by-stage photographs and instructions of the installation.

Jointing System Training

As part of the Network Rail accessories standard NR/L2/SIGELP/27423, Network Rail has included a specific requirement for training and competence on the accessory:

"Manufacturers shall have a comprehensive training programme that supports their product range. Note: Human factors and good workmanship drive asset life, without which the risk of premature failure becomes increasingly high. Successful completion of the training course shall be recorded in the candidate's parent company's competence management system." (Network Rail, 2015)

It is clear that in order to meet the +35 years life expectancy of Network Rail the approved joints must be installed exactly as those tested and approved. Therefore, the requirement for specific training on the approved jointing system makes perfect sense. For some this training will be a refresher but, for those new to the industry, this training will be an entry point into the world of cable jointing.

The Prysmian Group training course is designed to give the delegates the knowledge and practical skills to joint two core and four core aluminium and copper rail signalling power distribution cables using the approved Prysmian Group RPJ enhanced cold pour resin joint kits. The course includes both classroom theory and practical sessions to ensure that the trainees can correctly and safely specify and install the Prysmian Group RPJ joints.

The course includes transferable skills such as:

- » Electrical site safety.
- » Best practice for reliable jointing of 1kV power cables.
- » Understanding the risks of poor jointing and how to mitigate them.
- » Understanding the perceived issues associated with jointing aluminium conductors.
- » Safe cable handling methods (during jointing process).
- » Identifying types of rail signalling power cable and understanding how to prepare them using the correct cable preparation tools and materials

The course also offers system specific skills such as:

- » Selection of the correct joint kit for a specific installation and cables.
- » Conductor preparation – particularly to overcome aluminium oxide build up prior to crimping.
- » Demonstrating the correct crimp and die selection to produce reliable compression connections.
- » Mixing and pouring of the approved JEM cold pour resin.
- » Construction of the RPJ series joint kits in accordance with the Network Rail approved Prysmian Group jointing instructions.

Over the two-day course, trainees will receive both classroom theory and hands on practical sessions whereby, following expert demonstrations, they will get the opportunity to practice making their own cable joints. The course is concluded with an assessed multiple-choice theory questionnaire and the preparation of an assessed cable joint. Successful participants will receive a certificate of competence and the commensurate level of CPD hours.

Network Rail has developed a robust set of standards for cables and accessories for signalling power cables. These standards are ensuring the networks of the future are robust and live up to the high expectation of the UK travelling public and Network Rail itself. With the direction of Network Rail, Prysmian Group has developed a range of cable joints that facilitate the requirement for a long lasting, robust, and easily maintainable signalling power network. From training courses that have been completed to date, feedback suggests such an event adds value to the already approved product and enhances the probability of making better joints on the Network Rail system. ●



THE UK'S LEADING MEDIA GROUP DEDICATED TO THE RAIL INDUSTRY



Connecting the UK rail industry for over 25 years.



www.rail-media.com